

INSTALLATION INSTRUCTIONS

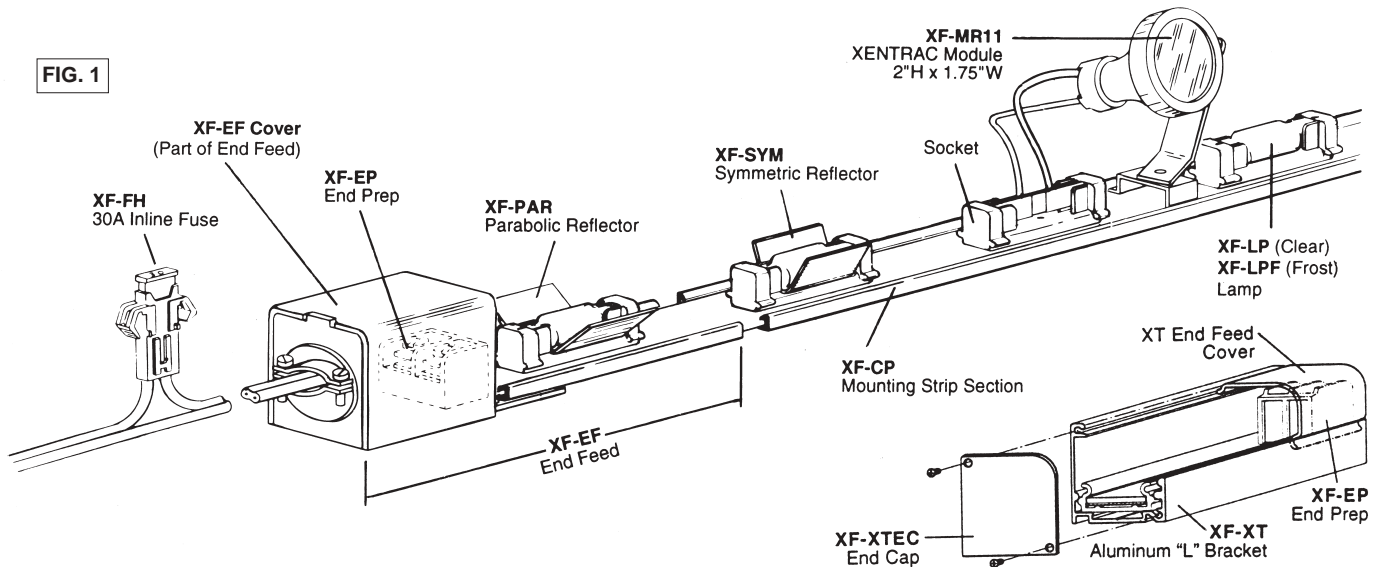

- IMPORTANT:**
- XENFLEX SHOULD BE INSTALLED BY A QUALIFIED ELECTRICIAN.
 - XENFLEX IS A LOW VOLTAGE SYSTEM, A TRANSFORMER IS REQUIRED FOR PROPER OPERATION!
 - MAKE SURE TRANSFORMER VOLTAGE AND CAPACITY MATCH XENFLEX RUNS.
 - FUSING OF EACH SECONDARY LEG IS MANDATORY. FOLLOW NATIONAL ELECTRICAL CODE.
 - 10 WATT LAMPS ARE NOT SUITABLE FOR BURNING IN THE LAMP DOWN POSITION.

1. XENFLEX IS ALWAYS MOUNTED USING THE XF-CP MOUNTING STRIP. FAILURE TO USE THE XF-CP MOUNTING STRIP MAY CAUSE AN ELECTRICAL HAZARD. XF-CP Mounting Strip is supplied with screws for fastening to most surfaces. A mechanical fastener, not an adhesive, is recommended. If required, XENFLEX may be field trimmed. For mounting details see Fig. 3.
2. Slip XENFLEX under one edge of the strip as shown (see Fig. 2). Starting from one end, push down along other edge of XENFLEX with a screwdriver blade or other tool until the entire length has snapped into place.
3. XF-EF End Feed is an extension of the XF-CP Mounting Strip and forms the power input of the XENFLEX fixture (see Fig. 1). XF-EF End Feed may appear on both ends of XENFLEX. This allows split feed and daisy chain connections (see Fig. 4).

CONNECT ENCLOSED SPADE CONNECTORS TO #10 AWG FEED WIRE USING PROPER CRIMPING TOOL.

SCREW TERMINALS ON XF-EP END PREP MUST BE FULLY TIGHTENED. FAILURE TO DO SO COULD CAUSE A POOR ELECTRICAL CONNECTION, AND OVERHEATING OF THE END PREP!!!

Consult Wire Gauge Table on reverse side to determine appropriate wire gauge for load. Consult Data Table on reverse side for maximum run lengths.

4. Make certain that XF-EF Cover is securely fastened.
5. To insert XF-LP Lamps, align loops into grooves at end of sockets and push downward with light pressure. A soft "snap" will be felt at each end of the lamp, if not, turn lamps over and reinsert. If used, XENFLEX Reflectors should first be fully seated so lamps can be inserted properly (see Fig. 1).
6. If XF-MR XENTRAC modules are used, (see Fig. 1) do not refer to the Data Table for maximum run lengths. A calculation based on total module and XENFLEX lamp wattage is required. Each 12 volt module dissipates 20 watts for a maximum of 360 watts.

FIG. 2

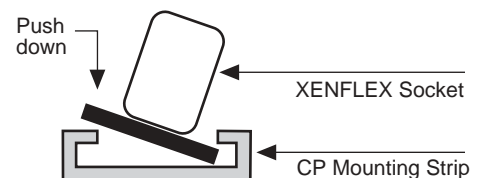
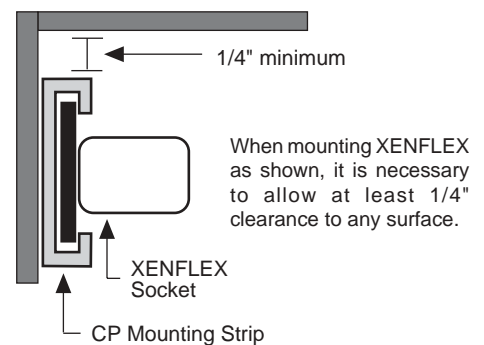

FIG. 3



starfire™
LIGHTING INCORPORATED

7 Donna Drive, Wood-Ridge, NJ 07075
800-443-8823 FAX: 201-438-9541

TYPICAL INSTALLATION

FIG. 4

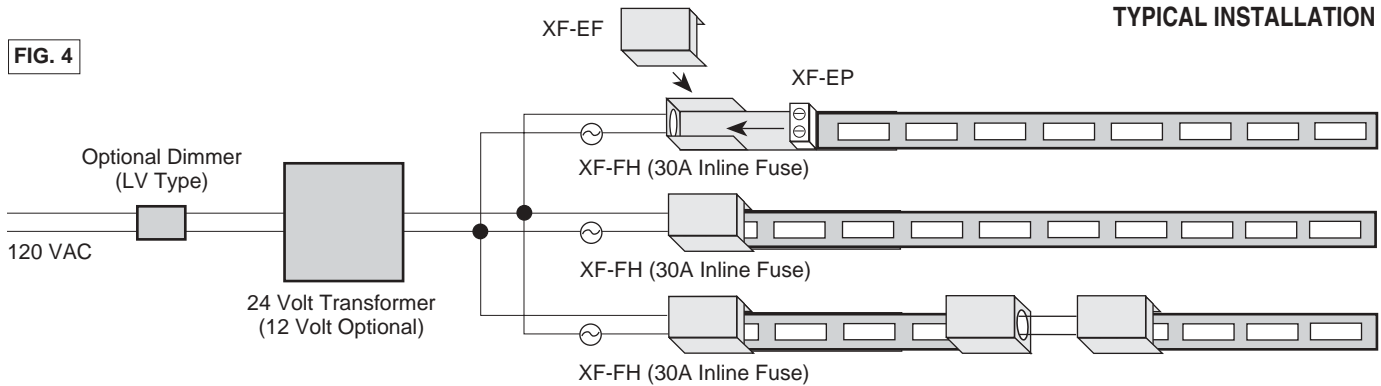

HIGH CURRENTS

A typical **XENFLEX** strip may dissipate 720 watts at 24 Volts. This corresponds to a current of 30 amperes. Consult appropriate codes for wire gauge required to safely handle the current. Consult [Data Table](#) below to determine maximum allowable run length of the **XENFLEX** fixture itself. Note that certain wiring techniques, such as powering two **XENFLEX** strips by feeding in the middle with a “Y” type connection, require that the main power feeds be able to carry the load of both halves, or 60 amperes.

VOLTAGE DROP

The length of the conductors is a critical factor. There will be a drop in the secondary voltage even in short runs. This can very quickly lead to unacceptable dimming of the load. Thus, even properly sized conductors may be insufficient to maintain the secondary voltage from the source to the load. The installer may increase the conductor size, add additional conductors, or shorten the lead lengths. The final voltage should be checked with a meter and should read no less than 5% of rated voltage under power. Measure at the **XF-EF** End Feed, not the transformers. See [Wire Gauge Table](#) below for appropriate power feed lengths.

Secondary feeds should be of equal length. This will prevent some sections from appearing brighter than others.

DATA TABLE

PARAMETERS		24 VOLT STANDARD DATA			12 VOLT OPTIONAL DATA		
SPACING	WATTAGE	MAX LENGTH	AMP/FT	WATTS/FT	LUMENS/FT	MAX LENGTH	AMP/FT
2"	5 Watt	20'	1.00	30	300	10'	2.10
2"	10 Watt	10'	2.00	60	900	5'	4.20
3"	5 Watt	30'	0.70	20	200	15'	1.40
3"	10 Watt	15'	1.40	40	600	7.5'	2.80
4"	5 Watt	40'	0.50	15	150	20'	1.05
4"	10 Watt	20'	1.00	30	450	10'	2.10
6"	5 Watt	60'	0.35	10	100	30'	0.70
6"	10 Watt	30'	0.70	20	300	15'	1.40

In order of importance, secondary feeds should be:

1. Of sufficient capacity
2. As short as possible
3. Of equal length

WIRE GAUGE TABLE (24V)

WATTAGE	#10 AWG	#12 AWG	#14 AWG	#18 AWG
100	80'	50'	35'	15'
200	60'	35'	20'	5'
300	40'	25'	15'	5'
400	30'	15'	10'	—
500	20'	15'	5'	—
600	20'	10'	5'	—
700	15'	10'	5'	—

WIRE GAUGE TABLE (12V)

WATTAGE	#10 AWG	#12 AWG	#14 AWG	#18 AWG
100	30'	15'	10'	—
200	15'	10'	5'	—
300	10'	5'	—	—
400	5'	—	—	—
500	5'	—	—	—
600	5'	—	—	—
700	—	—	—	—